

AXiA XL

SBS12N2TF Series

SIT-ON STACKERS WITH TELESCOPIC FORKS

1.2 tonnes

INCREASE YOUR STORAGE DOUBLE YOUR REACH

AXiA sit-on stackers are a flexible and cost-effective choice for stacking and internal transport in warehousing, manufacturing, and anywhere else safe, productive stacking is required. Many companies use reach trucks for stacking tasks, but they may be over specified for the task. For these jobs the AXiA sit-on stacker makes an excellent low-cost alternative.

AXiA XL models with telescopic forks enable more flexible handling of long loads and work with double deep racking setups. Double deep racking stores four pallets between aisles, reducing storage cost per square meter by up to 17% and increasing pallet locations by 25–30%.

SPECIFICATIONS

SBS12N2TF

WHEN
**RELIABILITY IS
EVERYTHING...**



AXiA XL

SBS12N2TF Series

SIT-ON STACKER WITH TELESCOPIC FORKS

1.2 tonnes



BRAKES

- **High-efficiency regenerative braking**
This gives more effective control and reduces brake wear.

DRIVE

- **Powerful AC drive motor**
High torque for greater efficiency. No carbon brushes mean lower servicing requirements.
- **Intelligent Cornering System**
The truck senses the angle of a turn and reduces speed early for maximum stability and accurate, positive cornering.
- **Automatic Speed Reduction**
Drive speed is automatically limited when forks are above 1.2m to allow higher capacities above that height.

ELECTRICAL AND CONTROL SYSTEMS

- **Built-in Li-ion battery**
Fast opportune charging removes the need for extra batteries and allows 24/7 operation. (Junior chassis only)
- **Convenient charging**
An extra battery plug on the outside of the truck allows for easy charging without needing to disconnect the internal battery plug. (Lead acid batteries).
- **Combi controller lift system**
Fingertip control for speed regulated lifting and proportional valve for lowering.
- **Enhanced Stability System (ESS)**
4-point chassis for maximum stability, drive speed is reduced when forks are lifted, and acceleration is reduced when steering angle exceeds 45 degrees.

FORKS AND MAST

- **Level Assistance System**
Automatically detects the operator's intention and automatically stops when the forks are at precisely at the right level. (Option)
- **Laser positioning guide**
Aligning the red laser line with the centre of the pallet pocket allows the driver to quickly ensure the forks are in the desired position. (Option)
- **Robust, clear view mast**
Optimised design means excellent visibility of the forks and load.
- **Exceptionally smooth 'no knock' transition between mast stages**
Vulkollan dampers ensure quieter movement over the lift range.
- **Smooth landing of the fork carriage**
Hydraulic attenuation in the free-lift cylinder makes this much quieter.
- **Hydraulic telescopic forks**
Speed regulated for greater precision and safer operation.
- **Longer reach**
Telescopic forks allow for handling of longer goods and greater reach across lorry beds.
- **Wide Straddle Legs**
These feature single wheels as standard with tandem wheels as an option. 750mm width standard, 950mm option.

FRAME AND BODY

- **Robust chassis**
Built for intensive operations, with great inherent strength and high residual capacities. Designed to enclose the operator within for extra safety.
- **Strong battery lock**
Simple and safe. Battery lock can only be unlocked when battery plug is disconnected. Battery plug can only be reconnected if battery is locked.
- **Excellent ground clearance**
Easy and safe handling on loading docks and ramps.
- **RapidAccess features**
These allow quick and easy entry to all areas for checks and maintenance.
- **Waterproof wiring and connectors**
Sealed compartment prevents system failure and corrosion from water and dust.
- **Overhead guard pillars**
Protection for the operator while still offering excellent visibility.



For more information on AXiA XL please visit our website



mft2.eu/axiaxlsbs

AXiA XL

SBS12N2TF Series

SIT-ON STACKER WITH TELESCOPIC FORKS

1.2 tonnes



HYDRAULICS

- **Smooth, quick lifting and lowering**
High levels of control and productivity. Low noise means less fatigue for the operator over long shifts.
- **Mast damping**
Soft landing and seamless transition in the mast stages provides low noise and vibrations when lifting or lowering.

OPERATOR COMPARTMENT AND CONTROLS

- **Comfortable seat**
Adjustable so drivers can find their ideal working position for less fatigue over long shifts.
- **Plenty of storage space**
Storage for on-board essentials, putting clipboard, mobile phone, drinks bottle and pen all within easy reach.
- **Ultra-low step height**
Operators stay more productive throughout shifts thanks to easy on/off access.
- **Direction switch on handle**
Alternative for drivers who prefer hand control rather than direction control on a pedal. Standard with cold storage modification or 360-degree steering. (Option)
- **Temperature controlled fans**
Low noise for a more comfortable working environment.
- **Adjustable floor height**
More adaptable working position to suit a wide range of operator heights. (Option)

STEERING SYSTEM

- **Mini steering wheel with floating armrest**
Fully ergonomically adjustable, its unique design allows the operator to adopt a more relaxed and natural driving position. This reduces arm and shoulder strain and lowers the risk of RSI.
- **360-degree steering**
The operator can keep the truck in constant motion - saving seconds on every turn. (Option)
- **Dynamic Power Steering**
Smooth, precise control with minimum effort offering maximum comfort and stability at top speed.



For more information on AXiA XL please visit our website





AXIA XL OPTIONAL LI-ION BATTERY SYSTEMS

MAKE YOUR FORKLIFT GO EVEN FURTHER



Tried, tested and proven in the field, lead-acid batteries have been the long-standing choice for companies employing electric lift trucks. However, with long charging times, demanding maintenance requirements, the need for extra batteries, and high risk of operator misuse, day-to-day use can be a challenge.

Fortunately, there's a new battery system on the block: Li-ion from Mitsubishi Forklift Trucks.

Designed to meet your business' demands — including multi-shift (24/7) operations — without the need for spare batteries, our high-performance Li-ion battery system is up to 30% more efficient than lead-acid counterparts. Plus, it's virtually error-proof, thanks to its ultra-low-maintenance design which prevents cell damage.

- **Gas-emission free**
No need for air ventilation.

- **Exceptional high battery and charger efficiency**
State-of-the-art technology delivers up to 30% more power efficiency than lead-acid batteries.
- **Maintenance-free design**
No need for daily checks and water re-fills. This reduces the risk of operators damaging cells and reducing their lifetime. Needs a full charge each week to activate cell balancing.
- **No need for spare batteries or charging room**
You can save both space and costs in multi-shift applications, maximising profitability.
- **Quick charge capabilities**
Just 15 minutes is all your battery needs to keep your truck going for a few more hours. It only takes 1 to 2 hours to fully charge a completely discharged battery.
- **Higher sustained voltage**
This gives more consistent lifting and driving performance — particularly noticeable towards the end of a shift.
- **Multiple safety features**
This includes circuit protection, deep-discharge and overcharge protection, and individual cell temperature and voltage monitoring.
- **On-the-go performance and monitoring**
The system's integrated monitoring system has an easy-to-read display unit.
- **Wide choice of battery and charger capacities**
The most suitable power supply can be matched to the exact requirements of a specific application.



Li-ion battery option is available in selected regions.

Continuing improvement may lead to changes in these specifications

Clean Li-ion batteries are ideal for sensitive environments such as those in the food or packaging industries.

Fully integrated Li-ion battery

Features a sophisticated CANbus communication and an automatic ON/OFF synchronization between battery and truck. Battery level, notifications and alarms are integrated into the truck display, to secure clear and easy overview for the truck operator.

For more information on Li-ion please visit our website

mft2.eu/ion

VDI - PERFORMANCE & DIMENSIONS

CHARACTERISTICS			
1.1	Manufacturer		Mitsubishi Forklift Trucks
1.2	Manufacturer's model designation		SBS12N2TF
1.3	Power source		Battery
1.4	Operator type		Sit-on
1.5	Load capacity	Q	kg 1200
1.6	Load center distance	c	mm 600
1.8	Load wheel axle to fork face (forks lowered)	x	mm 714
1.9	Wheelbase	y	mm 1660 ²⁾
WEIGHT			
2.1b	Truck weight without load, with maximum battery weight		kg 2178
2.2	Axle loadings with nominal load & maximum battery weight, drive / load side		kg 1545 / 1833
2.3	Axle loadings without load & with maximum battery weight, drive / load side		kg 1525 / 653
WHEELS, DRIVE TRAIN			
3.1	Tyres: PT = Power Thane, Vul = Vulkollan, P = Polyurethane, N = Nylon, R = Rubber drive / load side		Vul / Vul
3.2	Tyre dimensions, drive side		mm 250 x 105
3.3	Tyre dimensions, load side	ø	mm 150 x 55
3.4	Castor wheel dimensions (diameter x width)		mm 150 x 55
3.5	Number of wheels, load / drive side (x = driven)		2 / 1x + 2 ¹⁾
3.6	Track width (center of tyres), drive side	b10	mm 706
3.7	Track width (center of tyres), load side	b11	mm 850 / 1050
DIMENSIONS			
4.2a	Height with mast lowered	h1	mm see tables
4.2b	Height	h1	mm see tables
4.3	Free lift	h2	mm see tables
4.4	Lift height	h3	mm see tables
4.5	Height with mast extended	h4	mm see tables
4.6	Initial lift	h5	mm -
4.7	Height to top of overhead guard	h6	mm 2110
4.8	Seat- or stand height	h7	mm 966
4.10	Height of support legs	h8	mm 110
4.15	Fork height, fully lowered	h13	mm 65
4.19	Overall length	l1	mm 2347 ²⁾
4.20	Length to fork face	l2	mm 1147 ²⁾
4.21	Overall width	b1	mm 1010 / 1150 ⁸⁾
4.22	Fork dimensions (thickness, width, length)	s/e/l	mm 57 / 169 / 1200
4.23	Fork carriage to DIN		FEM 3/A
4.24	Fork carriage width	b3	mm 820
4.25	Outside width over forks (minimum / maximum)	b5	mm 578 / 842
4.26	Inner width of support legs	b4	mm 750 / 950 ⁸⁾
4.28	Mast reach travel	l4	mm 850 ³⁾
4.32	Ground clearance at center of wheelbase, (forks lowered)	m2	mm 40
4.33a	Working aisle width (Ast) with 1000 x 1200 mm pallets, load crosswise	Ast	mm 2726
4.34a	Working aisle width (Ast) with 800 x 1200 mm pallets, load lengthwise	Ast	mm 2690
4.35	Turning radius	Wa	mm 1861
4.37	Truck length including support legs	l7	mm 1966 ²⁾
PERFORMANCE			
5.1	Travel speed, with / without load		km/h 8.0 / 8.0
5.2	Lifting speed, with / without load		m/s 0.15 / 0.26 ⁴⁾
5.3	Lowering speed, with / without load		m/s 0.38 / 0.38 ⁴⁾
5.8	Maximum gradeability with / without load		% 7.2 / 7.2
5.9	Acceleration time (10 metres) with / without load		s 6.5 / 5.5
5.10	Service brakes (mechanical / hydraulic / electric / pneumatic)		Electric
ELECTRIC MOTORS			
6.1	Drive motor capacity (60 min. short duty)		kW 2.7
6.2	Lift motor output at 15% duty factor		kW 8.0 ⁵⁾
6.4	Battery voltage/capacity at 5-hour discharge		V/Ah 24 / 465 ⁶⁾
6.5	Battery weight		kg 330-410 ⁶⁾
6.6a	Energy consumption according to EN16796 cycle		kWh/h 0.87 ⁷⁾
MISCELLANEOUS			
8.1	Type of drive control		AC
10.7	Level of noise at the ear level of the driver according to EN 12 053:2001 and EN ISO 4871 in work LpAZ		dB(A) <70

AXIA XL

SBS12N2TF Series

SIT-ON STACKER WITH TELESCOPIC FORKS

1.2 tonnes

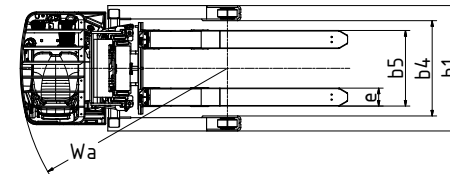
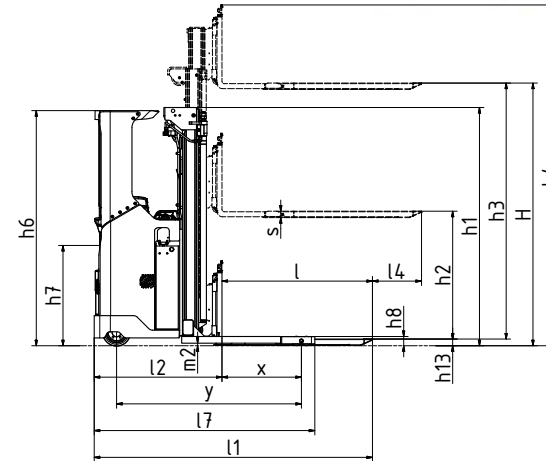

Ast = Working aisle width
Ast3 = Working aisle width (b12 < 1000 mm)
 $Ast = Wa + \sqrt{(l6 - x)^2 + (b1^2 / 2)^2} + a$
Ast3 = Wa + l6 - x + a
Wa = Turning radius
l6 = Pallet length
x = Load wheel axle to fork face
b12 = Pallet width
a = Safety clearance = 2 x 100 mm

MAST TYPE	h3+h13 mm	h1 mm	h4 mm	h2+h13 mm
TELESCOPIC FORKS				
SBS12N2TF				
DTFV / TREV	4800	2150	5750	1225
	5400	2350	6350	1425
	5700	2450	6650	1525
	6300	2650	7250	1725

DTFV / TREV = Triplex with full free lift
h3+h13 = Lifting height (fork)
h1 = Lowered mast height
h4 = Raised mast height
h2+h13 = Free lift

All dimensional values, weights and measures vary according to configuration
1) 4-point design with twin assembly drive side castor wheels
2) When Senior (BC775) chassis then add 104 mm
3) Telescopic forks reach travel, optional reach 450-1000
4) Standard motor, not sufficiently tested with the 8.0 kW heavy-duty option yet
5) With heavy-duty lift motor, standard is 4.0
6) With Senior chassis, 24V / 560-775Ah and 460-610 kg
7) This is a reference test value that varies according to model, config and usage pattern
8) There are two standard straddle/support legs widths available to choose from (ref. b1/b4)

STANDARD EQUIPMENT & OPTIONS

- = Standard
- = Option

	SBS12N2TF
GENERAL	
Wide straddle legs for handling of closed load carriers	●
Telescopic forks for extended reach in handling of e.g. double-deep stacking and closed load carriers	●
Standard display incl. hour meter and battery indicator (BDI)	●
Key switch entry	●
Electric power steering, with Mini or Midi steering wheel	●
Automatic straight steering at start-up	●
Adaptive cornering control	●
Speed regulated lift motor and proportional valve for lowering	●
Tandem load wheels Vulkollan	●
Overhead guard (OHG)	●
Adjustable armrest, right side	●
Adjustable steering wheel, all directions	●
Storage compartment under armrest and by left side of seat	●
Ergonomic reach truck class and fully adjustable fabric clad seat	●
Battery on rollers	●
POWER SOURCE	
Li-ion batteries*	●
Lead acid batteries	●
ENVIRONMENT	
Chill store design, down to -10°C	●
Cold store design, 0°C to -30°C**	●
DRIVE, LIFT CONTROLS	
Mini steering wheel with floating armrest	●
Midi steering wheel	●
Finger tip controls for lifting/lowering	●
Hands-free direction control (HFDC), in accelerator foot pedal	●
Hand operated direction control (HODC)	●
360-degree steering	●
Reversed steering	●
WHEEL OPTIONS	
Vulkollan	●
Tractothan	●
Super grip	●
OTHER OPTIONS	
High performance lift motor system 8.0 kW AC	●
Electric adjustable floor height, 70 mm	●
Vinyl clad seat	●
Heated seat, fabric or vinyl	●
Multifunction display incl. BDI and hour meter, PIN code login (100 codes) and graphic icons	●
Key switch entry (in combination with multifunction display)	●
Load weight indicator	●
Lift height indicator	●
Level assistance system	●
Panoramic ProVision roof	●
12 V DC Power Socket	●
5 V USB socket	●
Accessory rack	●
Writing desk incl. RAM C holder	●
Equipment holder RAM system size C	●
Equipment holder RAM system size C, 2 pcs	●
Equipment holder RAM size D	●
Working lights LED	●
Floor spot warning, red or blue	●
Special RAL colour	●

AXIA XL

SBS12N2TF

SIT-ON STACKER WITH TELESCOPIC FORKS

1.2 tonnes



Standard display



Mini steering wheel with floating armrest



12 V DC Power Socket

* Li-ion battery option is available in selected regions.

** Li-ion battery option not in combination with cold store design, 0°C to -30°C.

WHEN RELIABILITY IS EVERYTHING...



AXiA
THE ALL ROUNDER

With a name that reflects its manoeuvrability, AXiA combines award-winning ergonomics with high performance and low-maintenance features to deliver a complete warehouse support package.

Efficient, versatile and durable, AXiA is the perfect choice for every workplace.

Like any product bearing the Mitsubishi Forklift Trucks name, our materials handling equipment benefits from the tremendous heritage, huge resources and cutting-edge technology of one of the world's largest corporations – Mitsubishi Heavy Industries Group.

Engineering spacecraft, jet planes, power plants and more, MHI specialises in those technologies where performance, dependability and superiority decide your success or failure...

So when we promise you quality, reliability and value for money, you know it's a guarantee we have the power to deliver.

That's why every model in our award winning and comprehensive range of lift trucks and warehouse equipment is built to a high specification – to ensure it keeps working for you. Day after day. Year after year. Whatever the job. Whatever the conditions.

YOU'LL NEVER WORK ALONE

As your local authorised distributor, we are here to keep your trucks working – through our extensive experience, our technical excellence and our commitment to customer care.

We are your local experts, backed by efficient channels to the entire organisation of Mitsubishi Forklift Trucks.

No matter where you are, we are close by – with the capability to meet your needs.

Discover how Mitsubishi Forklift Trucks give you more from your local authorised distributor or when you visit our website www.mitforklift.com

Performance specifications may vary depending on standard manufacturing tolerances, vehicle condition, types of tyres, floor or surface conditions, applications or operating environment. Trucks may be shown with non-standard options.

Specific performance requirements and locally available configurations should be discussed with your distributor.

We follow a policy of continual product improvement. For this reason, some materials, options and specifications could change without notice.

QUALITY | RELIABILITY | VALUE FOR MONEY

info@mitforklift.com

WESM2412 (11/23) © 2024 MLE

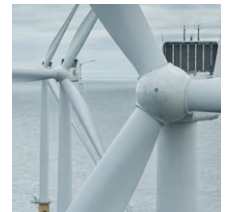

Mitsubishi Logisnext Europe B.V.
Hefbrugweg 77, 1332 AM Almere
The Netherlands
Tel: +31 (0)36 5494 411



mft2.eu/fb



mft2.eu/apps



mft2.eu/youtube



mft2.eu/facebook

